

CCS 800 Ultra



Security Systems

en | Installation and Operating Manual
Discussion System



BOSCH

Table of Contents

1. About this manual	5
2. Introduction	5
3. Central Unit (CU)	6
4. Delegate and Chairman unit	7
5. Installation	7
5.1 Connecting the delegate and chairman units	7
5.2 Connecting up to 150 units	8
5.3 Locking the extension cable	8
5.4 Connecting an external microphone	8
5.5 Connecting a wireless microphone	9
5.6 Recording/play back the conversation	9
5.7 Connecting a PA-system or other external equipment	9
5.8 Connecting a telephone coupler	9
5.9 Connecting an equalizer	10
5.10 Mains connection	10
5.11 Connecting a USB cable	10
6. Operation	11
6.1 Testing the connection of the delegate and chairman units	11
6.2 Using the microphone button of the delegate unit	11
6.3 Using the microphone button of the chairman unit	12
6.4 Using the priority button	12
6.5 Priority mode settings in chairman unit	12
6.6 Open mode	13
6.7 Open mode with auto switch-off	13
6.8 Override mode	14
6.9 Chairman only mode	14
6.10 Volume control of the delegate and chairman units	15
6.11 Using Digital Acoustic Feedback Suppression (DAFS)	15
6.12 Monitoring volume control	16
6.13 Using a headphone	16
7. Built-in MP3 recorder	17
7.1 Introduction	17
7.2 Overview	17
7.3 Setting up the MP3 recorder	18
7.4 Record	22
7.5 Pre-listen and Playback	24
8. Troubleshooting	26
9. Technical data	28
9.1 System Electrical and Electro-Acoustical Characteristics	28
9.2 Mechanical Data	29
9.3 General Data	29
10. Appendix	31
10.1 Pin Configuration	31
10.2 Mounting Instructions	32
10.3 Bracket for Flush Mounting	33

1 About this manual

This manual provides all the information required to install and operate the CCS 800 Ultro Discussion System.

Conventions



Warning

Warnings draw attention to instructions that must be followed to prevent personal injury.



Caution

Cautions draw attention to instructions that must be followed to prevent damage to the equipment.



Note

Notes draw attention to special instruction tips or other useful information.

2 Introduction

The CCS 800 Ultro Discussion System is a discussion system for use in meeting and conference venues with a limited number of participants.

A CCS 800 Ultro Discussion System consists of:

- One Central Unit (CU).
- Maximum 50 units of which one or more chairman unit(s).
- Extension cables if required (5m or 10m).
- Peripheral audio and/or telecommunication equipment.
- A built in MP3 recorder.

The **CU** is the heart of the discussion system which controls the microphones of the chairman and delegate units as well as providing facilities for audio inputs and outputs. It also supplies the power for the CU itself, chairman unit(s) and delegate unit(s).

With the use of Digital Acoustic Feedback Suppression the loudspeaker volume can be increased significantly before feedback appears. Digital Acoustic Feedback Suppression is only available in CCS-CUD / CCS- CURD.

A **delegate unit** enables participants to actively join in a discussion (i.e. speaking and listening) by means of a microphone, controlled by an on/off button and a built-in loudspeaker or external headphone.

A **chairman unit** has the same function as a delegate unit with the addition of a 'Priority' button, that enables its operator to control the debate by temporary or permanently overruling and muting all active microphones, depending on an internal setting in the chairman unit.

The built in **MP3 recorder** enables participants to: record discussion; listen to discussion before playing it back to the floor; play discussion back to delegates.

3 Central Unit (CU)

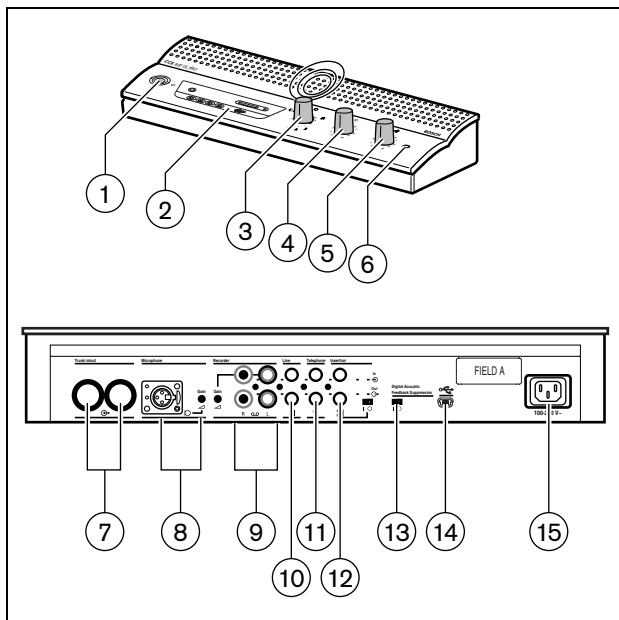





Figure 3.1

- 1 Mains On/Off switch.
- 2 MP3 recorder (for more information, see section 7).
- 3 Microphone-mode switch.

 **Open mode with auto switch-off.** To select the maximum number of delegate microphones to be activated simultaneously (1, 2, 3 or 4). The microphone automatically switches off if the speaker does not speak for 30 seconds. The microphone can manually be switched off by pushing the button on the delegate unit.

 **Open mode.** To select the maximum number of delegate microphones to be activated simultaneously (1, 2, 3 or 4). The microphone must be switched on or off manually by pushing the button on the delegate unit.

 **Override mode.** Only one delegate microphone can be activated. If a new delegate presses his microphone button, the microphone unit of the current speaker will be switched off.

 **Chairman only mode.** Only the chairman units can be activated.

 **Test mode.** For proper installation check. All the light-rings and LED's of the connected units will lit, if properly connected.

- 4 Speaker volume control of all connected delegate and chairman units.

- 5 Volume control of the speaker or headphone of the CU.
- 6 Headphone connection with 3.5 mm stereo jack plug socket.
- 7 Trunk output 1 and 2. For loopthrough connection of the delegate and chairman units. To each output a maximum of 25 units can be connected. The maximum length of cable between the outputs of the CU and the last unit in the system is 100 m (328 ft).
- 8 Microphone input with gain adjustment for external microphone. The external microphone will be muted when the priority button on the chairman unit is pressed.
- 9 Recorder input with gain control and recorder output connection.
- 10 Line input and output for connecting a PA-system or other audio equipment.
- 11 Telephone coupler input and output for connecting a remote participant.



Note

The telephone input signal to the CU is not added to the telephone output signal from the CU to prevent line echo due to feedback.

- 12 Insertion connection. To connect an external audio equalizer for speech quality improvement under difficult acoustic conditions (1 = without equalizer, 0 = insertion connection is internally open, providing means to connect an external equalizer in the path from microphone signals to delegate/ chairman loudspeakers).



Note

Position "1" required for internal loop-through of the microphone signals to the delegate/ chairman unit loudspeakers.

- 13 Digital Acoustic Feedback Suppression (DAFS) switch to activate or deactivate the DAFS (optional).
- 14 USB connector. Used for downloading recorded speech to a PC (optional).

15 Mains input connection. Use the included mains cord to connect the CU to the mains socket. In some countries it may be necessary to replace the supplied mains cable by a local one. Brown = live, blue = neutral and green/yellow = earth. (Replacement and colour indication not applicable to mains cords for North America).

4 Delegate and Chairman unit

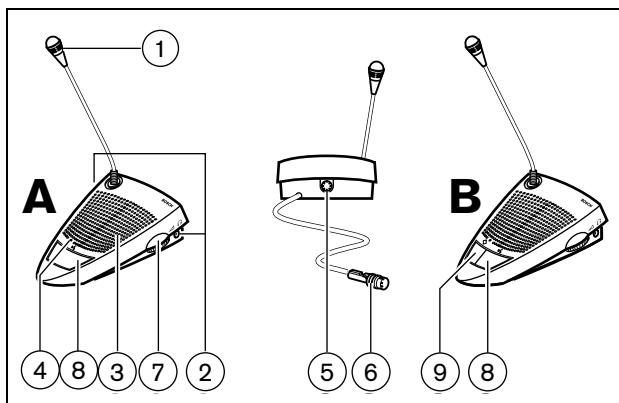



Figure 4.1

The chairman unit (B) has the same function as a Delegate unit (A) with the exception of a 'priority' button.

- 1 Microphone with red illuminated indicator ring, lights when the microphone is ON.
- 2 Two 3.5 mm stereo headphone sockets, one at each side, for headphone or recorder connection. Insertion of a headphone jack in one or both sockets automatically mutes the unit's loudspeaker.
- 3 Built-in loudspeaker, automatically muted when the microphone is on.
- 4 Red (LED) indicator above the microphone push button, for microphone ON indication.
- 5 7-pole circular female socket for loopthrough connection to the next unit.
- 6 2m flying lead connection cable with sturdy moulded 7-pole circular male connector for connection to the previous unit or CU.
- 7 Rotary volume control for headphones only.
- 8 Microphone ON/OFF push-button.

9 Chairman Priority button. When pressed emits chime tone, overrules/mutes all active microphones of delegate units in the system and keeps the chairman's microphone on for as long as the button is pressed (setting can be changed in the chairman unit). In systems with several chairman units these settings are independently selectable for each chairman unit.

5 Installation



Warning
The CU must be earthed via the mains supply for safety reasons and to ensure the specified audio performance of the system. Do not open the CU and/or delegate/chairman units, no user serviceable parts inside.

5.1 Connecting the delegate and chairman units

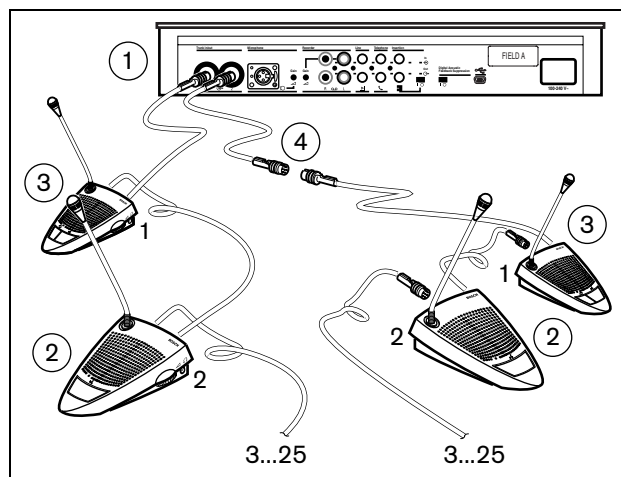

Figure 5.1

Connect the delegate (2) and chairman (3) units to the trunk connectors of the CU (1). Use an extension cable (4) if necessary.

5.2 Connecting up to 150 units

The CCS 800 Ultro can be used with up to 150 units by adding a maximum of 2 additional control units acting as power supply units only. The cables necessary for these connections can be delivered by your local dealer.

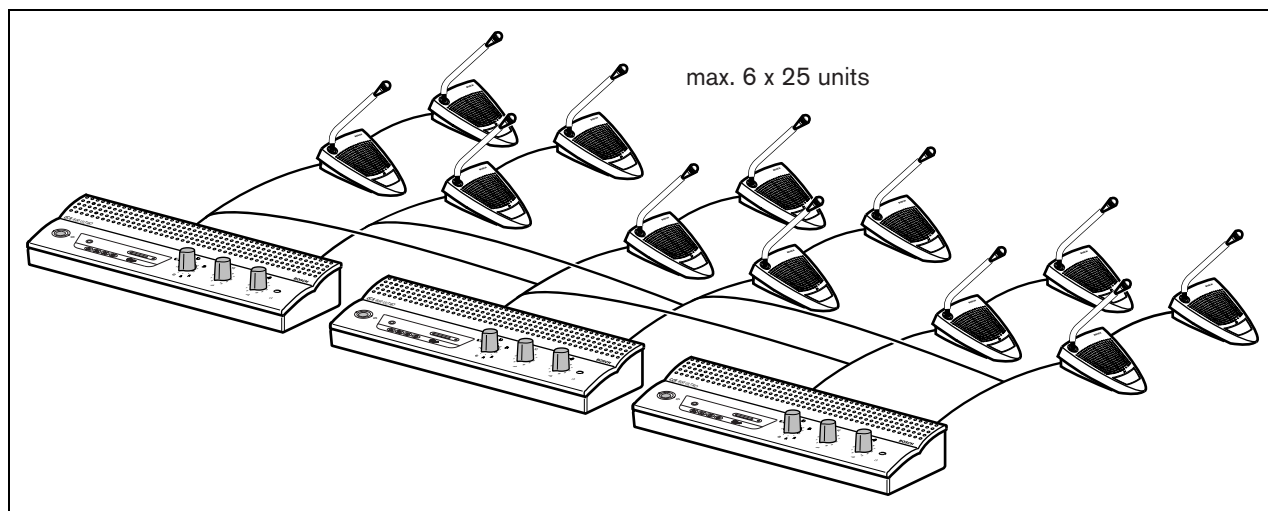

Figure 5.2

5.3 Locking the extension cable

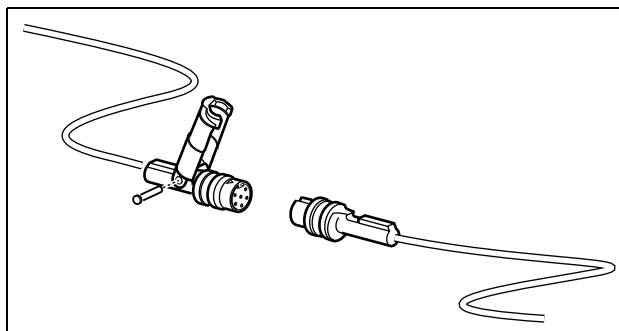

Figure 5.3

Cable locking clamps can be used in combination with the extension cables to prevent accidental disconnection.

5.4 Connecting an external microphone

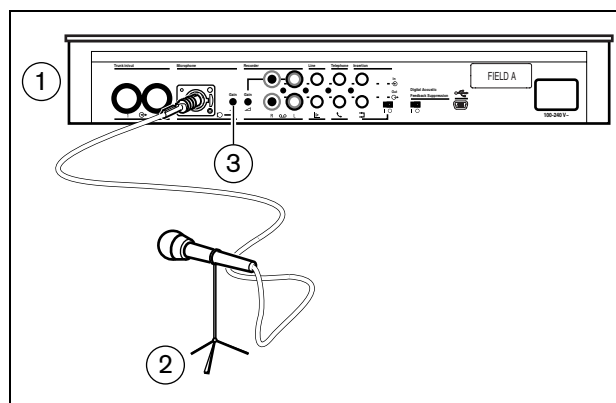

Figure 5.4

Put the external microphone (2) connector in the microphone input of the CU (1).
Adjust the sensitivity by use of the gain control (3).
Use only microphones with balanced output.
The microphone input provides a 12V phantom power supply.

5.5 Connecting a wireless microphone

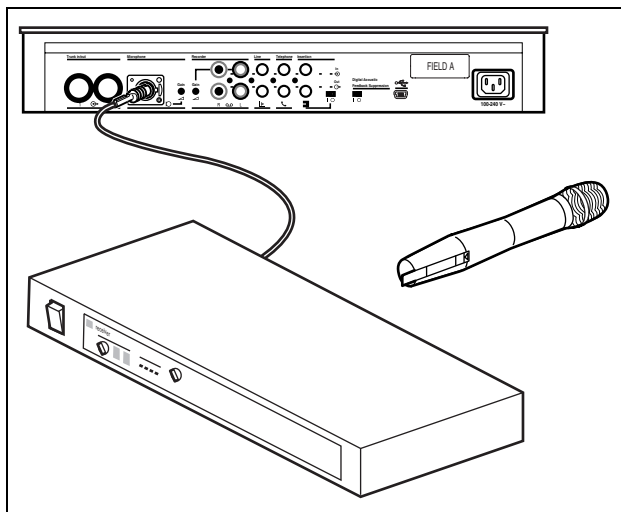

Figure 5.5

Connecting a wireless microphone to the external microphone input is possible with the included 50dB attenuator. This way of connection allows interruption of the wireless microphone by the chairman's priority button.

5.6 Recording/play back the conversation

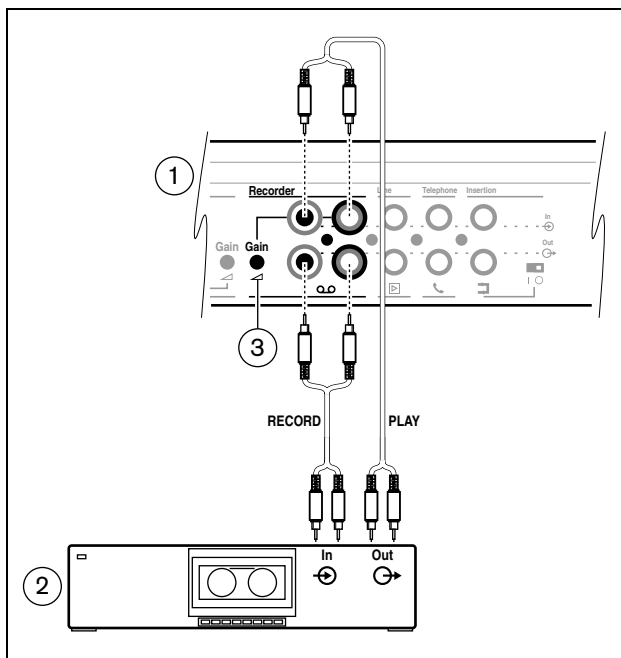

Figure 5.6

Connect the cabling of the tape recorder (2) to the recorder input and output of the CU (1). Use the gain control (3) to adjust the sensitivity of the recorder input of the CU.

5.7 Connecting a PA-system or other external equipment

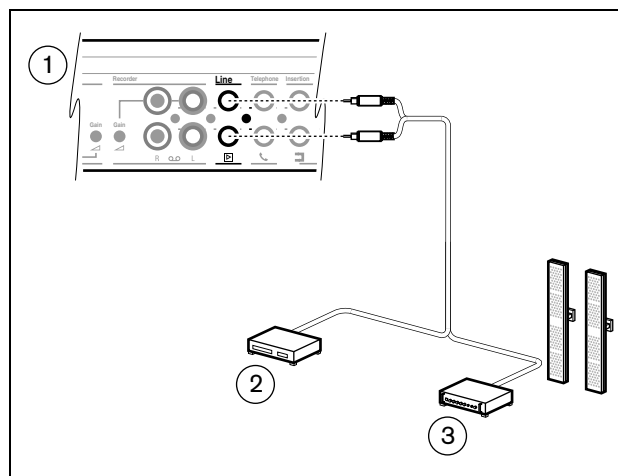

Figure 5.7

Connect a PA-system (3) or other devices (2) to the in- and output of the CU (1).

Connect audio sources to the line input, a PA amplifier or other sound-processing devices to the line output.

5.8 Connecting a telephone coupler

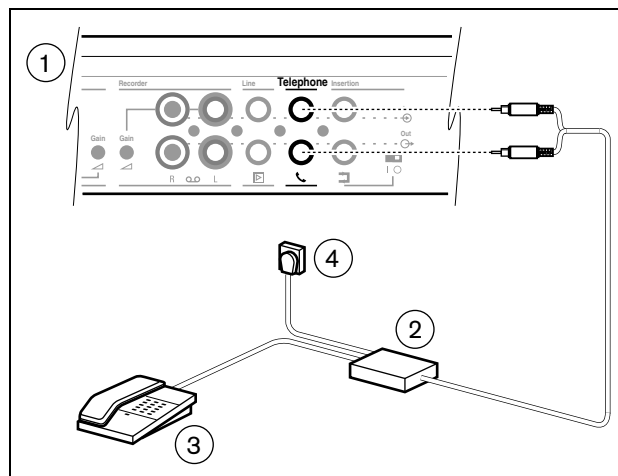



Figure 5.8

Connect the telephone coupler (2) to the telephone input and output of the CU (1). The telephone coupler is further connected to the telephone wall socket (4) and a telephone (3) for dialing.

A connection to a telephone network must always be made via a telephone coupler that provides adequate isolation between the telephone network (PBX) and the CCS 800 Ultra system. The telephone coupler shall also meet all relevant requirements for this type of communication equipment as imposed by law and/or responsible telecommunication organisations in the country of use.

 **Caution**
Never try to make a direct connection between the telephone network and the CCS 800 Ultra discussion system.

5.9 Connecting an equalizer

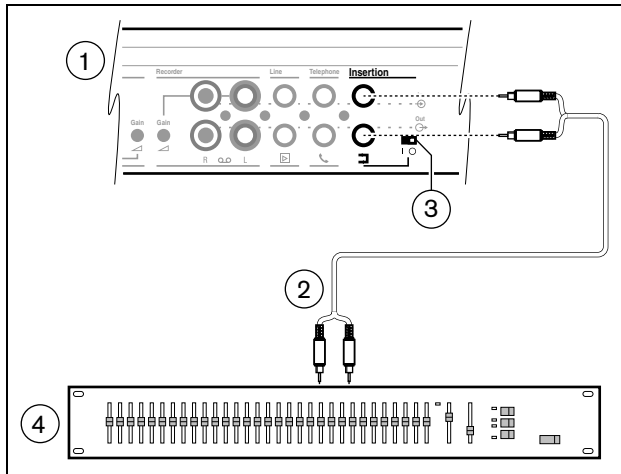

Figure 5.9

Put the insertion switch (3) in position "0" and connect the cabling (2) of the (mono) equalizer (4) to the insertion input and output of the CU (1). Switch (3) must be in position "1" (loop through) if the insertion input/output is not used.

5.10 Mains connection

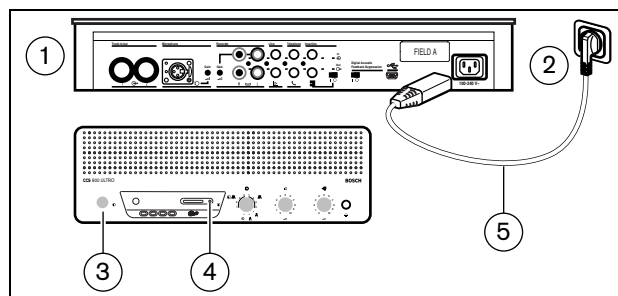



Figure 5.10

Use the supplied mains cord set (5) to connect the CU (1) to a protective earthed mains socket (2). Press the on/off switch (3) to power up the system, the display (4) will be lit.

5.11 Connecting a USB cable

Use the optional USB cable to connect the CU (1) to a PC. Data can then be downloaded from the CU to the PC. See section 7 for more information.

 **Caution**
Do not connect the USB cable and audio output/input to the same PC, otherwise the system will not work.

6 Operation

6.1 Testing the connection of the delegate and chairman units ☒

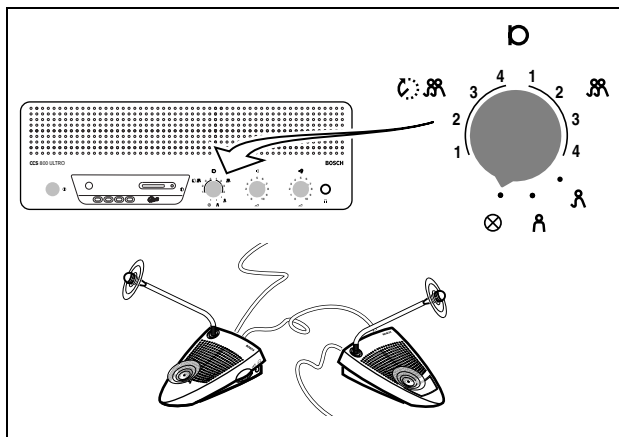

Figure 6.1

Put the mode selector in the test position, all light-ring indicators and LEDs of the delegate and chairman units must lit if properly connected.

6.2 Using the microphone button of the delegate unit ☒

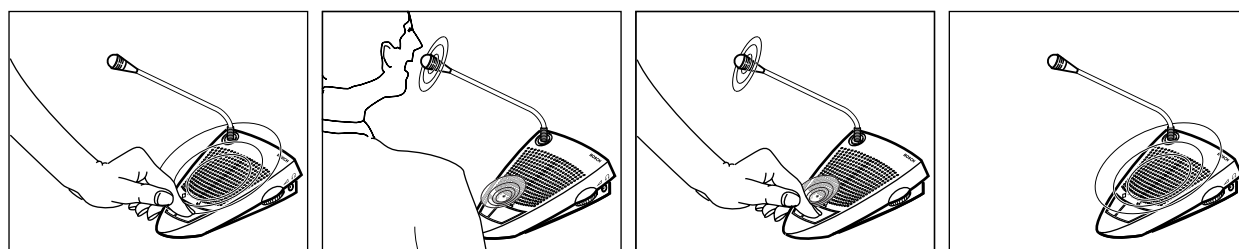

Figure 6.2

Depending on the position of the microphone mode switch on the CU, pressing the microphone button on a delegate unit will activate the delegate microphone. Pressing again switches the microphone off.

6.3 Using the microphone button of the chairman unit

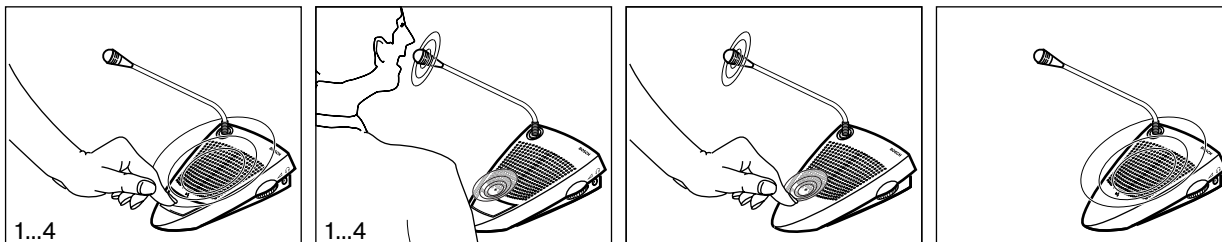

Figure 6.3

Pressing the microphone button on a chairman unit always activates the chairman microphone, independent of the selected microphone mode.
Chairman units don't switch off automatically.

6.4 Using the priority button

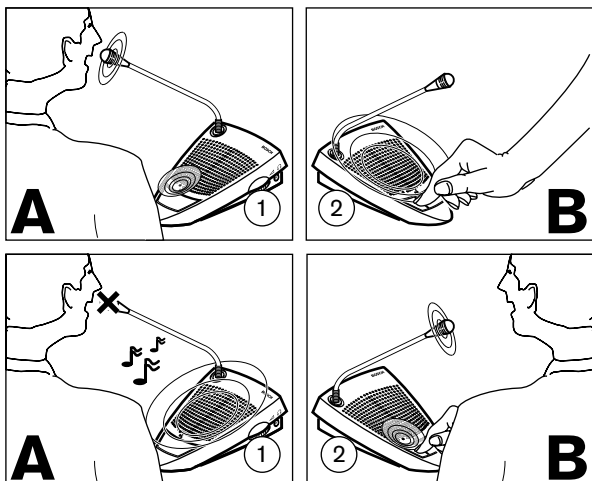

Figure 6.4

Pressing the priority button of the chairman unit "B" may be indicated by a chime tone and will deactivate all active delegate units "A" and activates the chairman microphone. Release of the button will either leave the delegate units deactivated or activates them again (depending on priority mode settings).

6.5 Priority mode settings in chairman unit

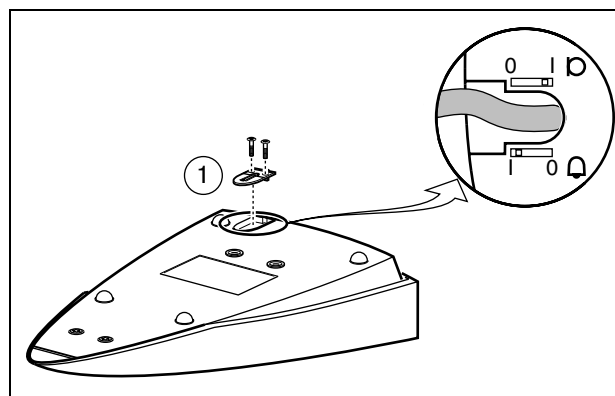







Figure 6.5

Remove the cable relief bracket (1) to set the chime and microphone switches in the required position at priority.

-  0 = : no chime at priority
-  1 = : (default) chime at priority
-  0 = : delegate microphones permanently OFF at priority
-  1 = : (default) microphones temporary OFF at priority

6.6 Open mode

Select the max. number (1, 2, 3 or 4) of delegate microphones which can be active at the same time.

 **Note**
Chairmen can always switch on and off their microphones and are not included in the max. number.

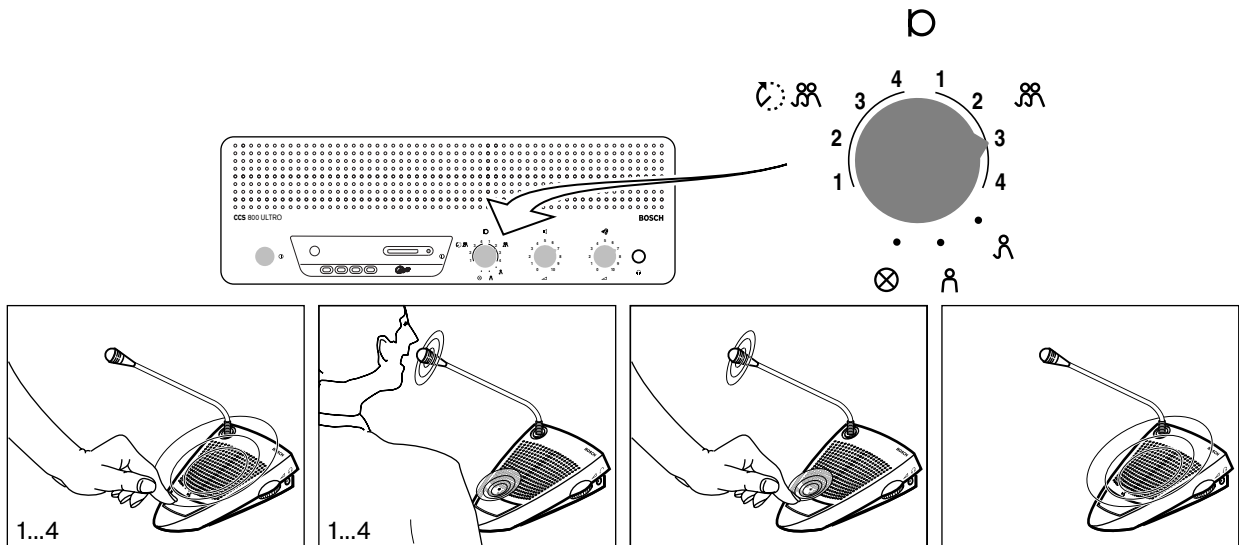

Figure 6.6

6.7 Open mode with auto switch-off



Select the max. number (1, 2, 3 or 4) of delegate microphones which can be activated by the delegates

themselves at the same time. If the speaker is silent for approximately 30 sec. the active microphone switches off automatically.

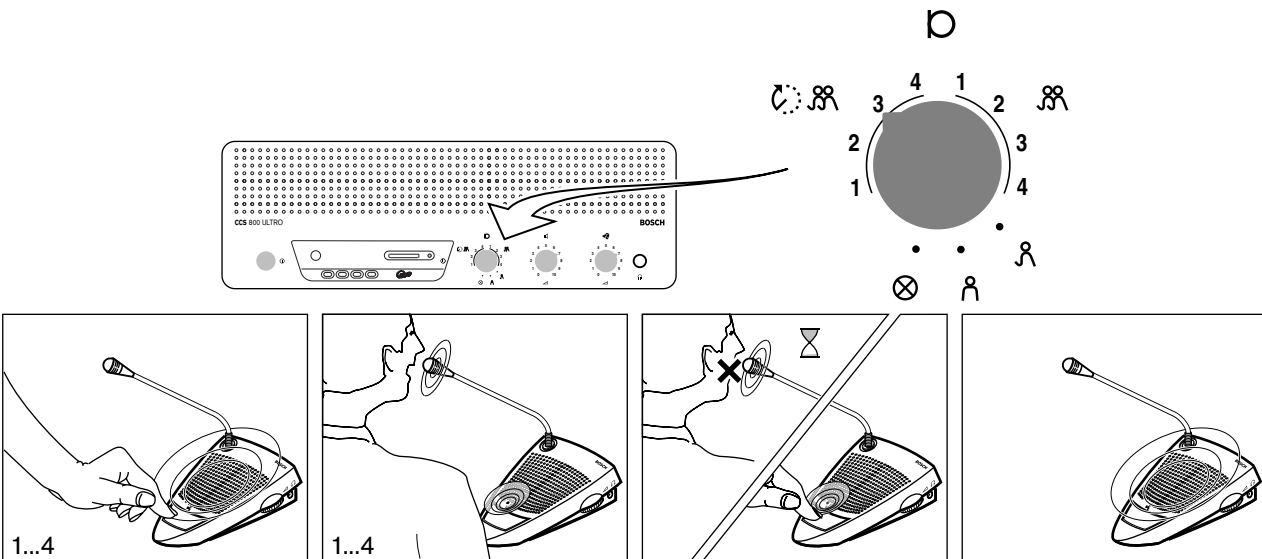

Figure 6.7

6.8 Override mode

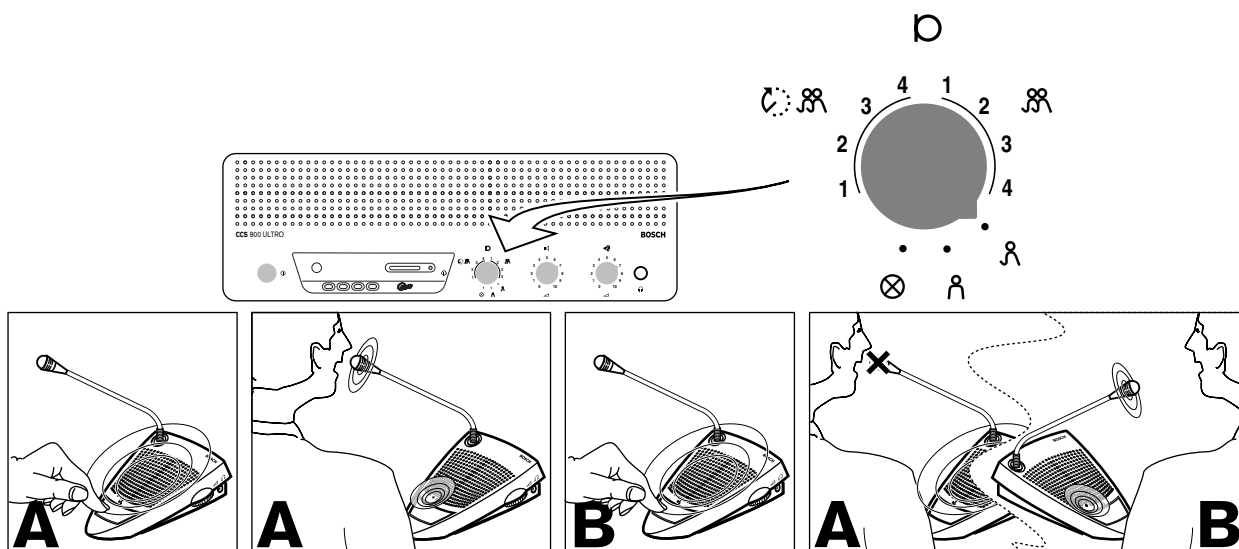

Figure 6.8

Each time a delegate presses the microphone button on a delegate unit, it will override the currently active delegate unit. So only one delegate microphone is active at the same time. Chairman microphones can always be switched on.

6.9 Chairman only mode

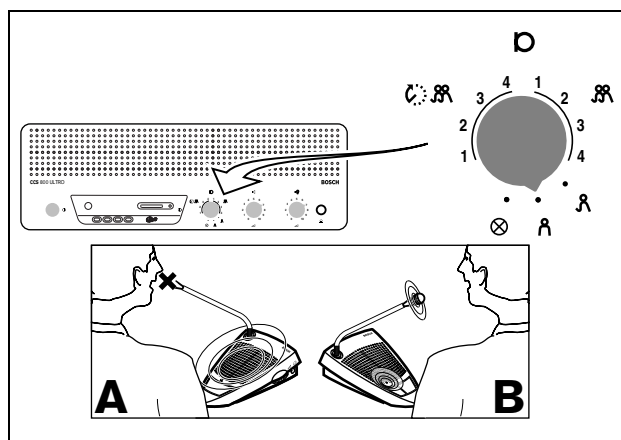

Figure 6.9

Only the chairman units (B) can be activated. Delegates (A) can not switch on their microphone.

6.10 Volume control of the delegate and chairman units

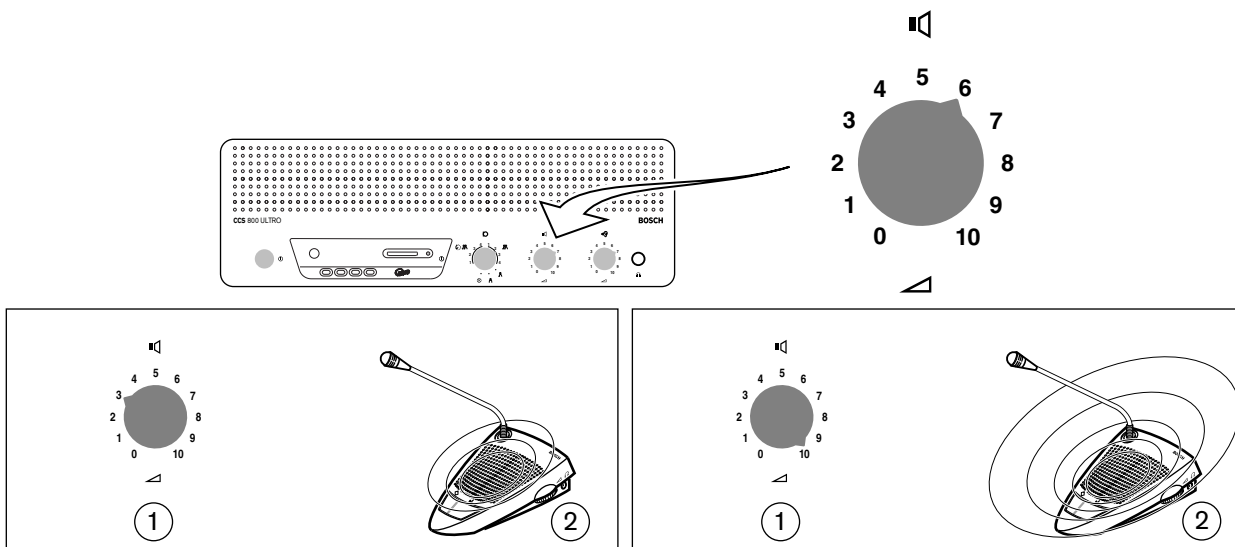

Figure 6.10

Turn the volume control (1) to set the volume of the loudspeakers of the delegate and chairman units (2). Adjust for maximum level without feedback. In the fully counterclockwise position all loudspeakers are muted.

6.11 Using Digital Acoustic Feedback Suppression (DAFS)

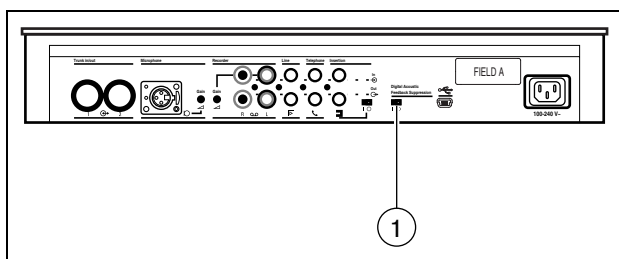

Figure 6.11

Put the Digital Acoustic Feedback Suppression switch (1) in position "0" and adjust the loudspeakers for maximum level without feedback. Switch Digital Acoustic Feedback Suppression on by changing the switch (1) to position "1". Then set the loudspeaker volume to the required level, but increasing the volume level more than 2 or 3 steps is not recommended.

Note

With the use of Digital Acoustic Feedback Suppression the loudspeaker volume can be increased significantly before acoustic feedback appears. The maximum achievable volume gain depends on the acoustical environment and positioning of the units. Artefacts may occur during microphone switching at very high volume levels. In general the achievable increased volume gain is 4 - 6 dB. The Digital Acoustic Feedback Suppression is optimised for speech.

6.12 Monitoring volume control

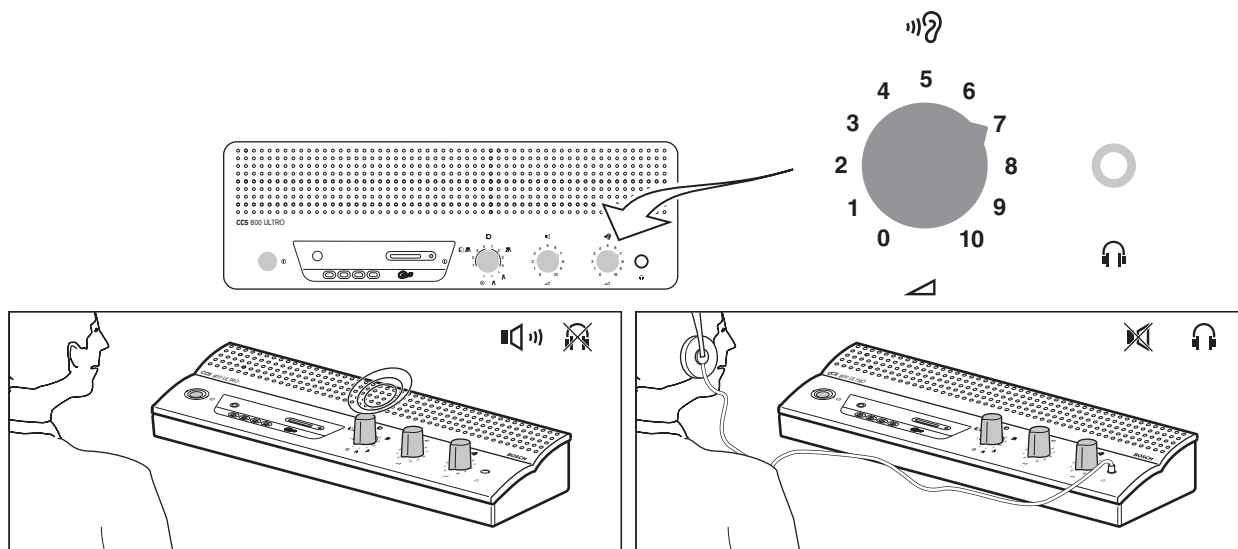

Figure 6.12

Use the built-in loudspeaker or a headphone to monitor the discussion. Adjust the volume using the monitoring volume control. The maximum level is controlled by the setting of the volume control for delegate and chairman units.

6.13 Using a headphone

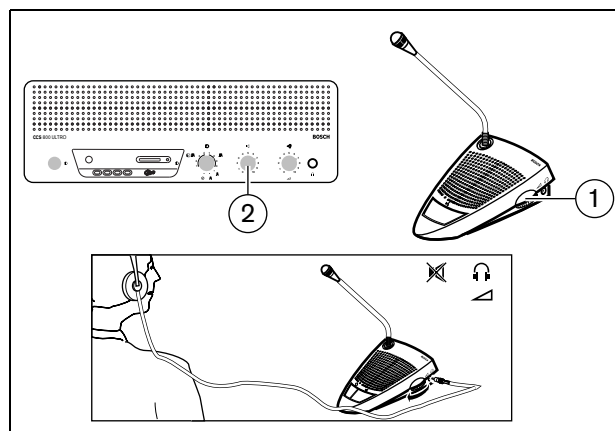

Figure 6.13

Use the rotary volume control (1) to adjust the volume of the headphones connected to the left and/or right side of the units. Inserting a headphone jack mutes the loudspeaker.

The maximum level depends on the setting of the volume control (2) on the CU.

7 Built-in MP3 recorder

7.1 Introduction

The built in MP3 recorder allows users to:

- record discussion
- listen to discussion before playing it back to the floor
- play discussion back to delegates

Recording is started and stopped by the user. The settings of the MP3 recorder can be changed so that recording only takes place when any one of the microphones is active (for more information, see section 7.3).

When recording is activated, the MP3 recorder will automatically create an MP3 file, using the current date and time as the file name. Recorded files have a maximum duration of 60 minutes. After 60 minutes, the file will be automatically closed, and a new file will be created. This process is repeated as long as recording is active or until the SD card is full.

Recorded speech is saved on an SD card, which is inserted into the top of the unit (see following figure), or saved internally. After recording, the SD card can be removed, or the recorded speech can be downloaded to a PC by connecting a USB cable to the back of the CCS 800 Ultro Central Unit.

The MP3 recorder has a card exchange feature that allows the user to exchange the SD card during conversation without loss of discussion/audio (for a full explanation of this feature, see section 7.4.3).

Once discussion has been recorded, the user can choose to pre-listen to or playback the file (for more information, see section 7.5).

7.2 Overview

7.2.1 User display

The user display has five soft buttons for operating the MP3 recorder (see following figure).

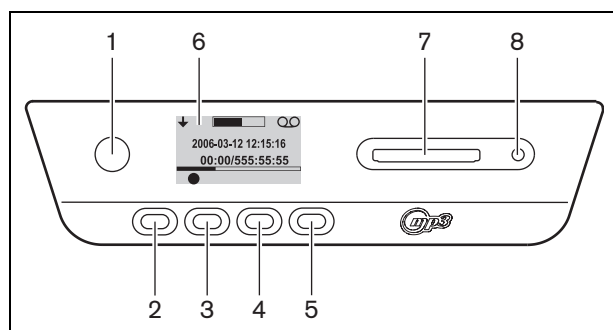





Figure 7.1: Overview of user display and buttons

- 1 **Soft button 1**
- 2 **Soft button 2**
- 3 **Soft button 3**
- 4 **Soft button 4**
- 5 **Soft button 5**
- 6 **User display:** displays user data and icons (see section 7.2.3).
- 7 **Slot for SD card:** Slot for inserting the SD card.
- 8 **LED for SD card:** LED is on during recording.

7.2.2 Modes of operation

Use button (1) to select the mode of operation. An icon appears in the top right-hand corner of the display to show which mode is selected. The following modes are available (see following table).

table 7.1: Mode selected icons

Icon	Mode selected
	Record
	Pre-listen
	Playback
	Set-up

7.2.3 Start-up screen

After powering up the CCS 800 Ultro, the start-up screen is briefly displayed, which shows the name of the recorder, as well as the revision number of the software.

The software then automatically displays the Record screen (see following figure).

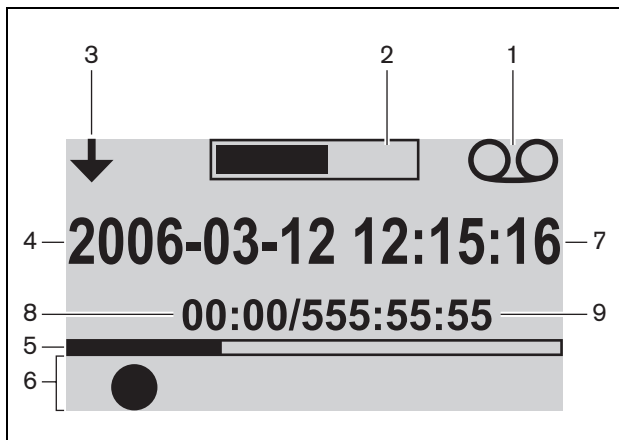

Figure 7.2: Overview of record screen (after start-up)

- 1 **Mode selected icon:** Shows the selected mode
- 2 **VU-meter:** Shows the audio level during recording, pre-listening, and playback.
- 3 **Change mode icon:** Shows the user when another mode can be selected.
- 4 **Date:** Shows the date in year, month, day format.
- 5 **Progress and separator line:** during recording shows the amount of used/free memory. In pre-listen mode and playback mode shows how much of the file has been played.
- 6 **Icons:** The space underneath the Progress and separator line is reserved for icons. Various icons are used during recording, pre-listening, and playback. The icons vary according to the mode selected (for more information, see section 7.3 through section 7.5).
- 7 **Time:** Shows the time in hours, minutes, and seconds.
- 8 **Time counter:** Shows the elapsed time during recording, pre-listening, and playback.
- 9 **Total time:** In record mode, shows the remaining time in hours, minutes, and seconds. The timer counts down during recording; in pre-listening mode, and playback mode, shows the total time of the selected recorded session. Note: Total time is constantly displayed.

















7.3 Setting up the MP3 recorder

Use this mode to set-up the MP3 recorder. The following options are available (see following table for an overview of the set-up icons):

- Delete files
- Set the date
- Set the time
- Select the bit rate
- Set recording to continuous
- Set recording options

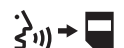
7.3.1 Overview of set-up icons

table 7.2: Overview of icons for navigating set-up screens

Icon	Icon name	Function of icon
	Next (displayed at lower left of set-up screen)	Go to next set-up screen. This icon is also displayed at the top left of the set-up screen to indicate that the other modes can be selected at any time, by pressing the change mode button (1).
	Select	Selects next value to change.
	Down	Decreases value, or selects another value or file.
	Up	Increases value, or selects another value or file.
	Date	Indicates that the date set-up screen is selected.
	Time	Indicates that the time set-up screen is selected.
	Bit rate	Indicates that the bit rate set-up screen is selected.
	Microphone recording	Unit will only record if one or more microphones are active.
	Constant recording	Unit will constantly record (one or more microphones do not have to be active).
	Confirm delete	Confirms file to be deleted.
	Delete file	Permanently deletes selected file.
	Cancel delete	Cancels the delete file command.
	Record to card	Sets up recording so that files are saved to the SD card. Data will still be saved to the internal memory during card exchange, as described in section 7.4.3.
	Record to memory	Sets up recording so that files are saved to the internal memory.
	Hourglass	Initializing SD Card.
	SD card status	Card flashing at 2 Hz: card is initializing. Card flashing at 5 Hz: card is either: full, write protected, or incompatible.

7.3.2 Deleting files

Use this option to delete files.

- 1 Press the up or down button to select the file to delete. The filename will change on the display as the button is pressed.
- 2 Press the confirm delete button to confirm the file to delete (the following screen will be displayed).

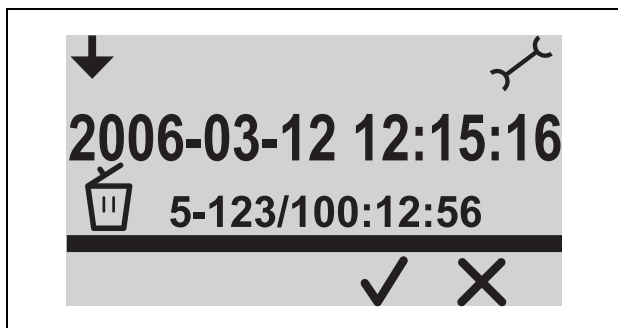
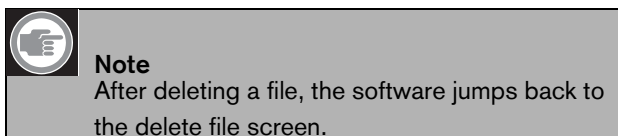

Figure 7.4: Confirm delete screen

- 3 On this screen, you can either:
 - select the delete file button to permanently delete a file.
 - select the cancel delete button to cancel the delete file command.



- 4 Press the select button to select the next value to change (see following section).

7.3.3 Setting the date and time



Note

To change settings in the set-up mode, you must follow the programmed sequence of events (there is no back button). To exit the set-up mode at any time, press the change mode button (button 1 at the left-side of the display).

Before using the MP3 recorder you should make sure that the date and time are correctly set. If necessary, adjust the date and time as follows:

- 1 Press the change mode button (1) to select the set-up mode. When selected, the set-up icon should be shown in the top right-hand corner of the display (see following figure).

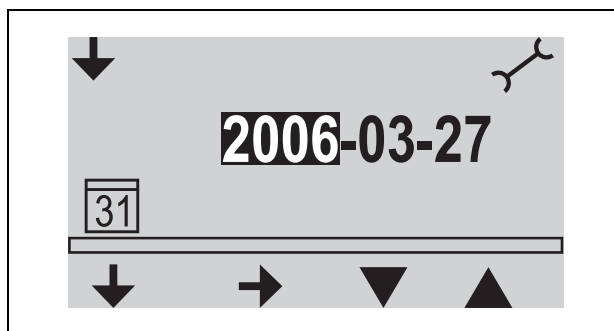

Figure 7.3: Set-up screen for date

- 2 Press the up or down button (4 or 5) to change the value (year number), and then press the select button (2) to select the next value to change.
- 3 Set the date (year, month, and day) as described in the previous step, and then press the next button (3) to jump to the time set-up screen.
- 4 Set the time (hours, minutes, and seconds), using the same method as described in step 2, and then press the next button to jump to the bit rate set-up screen (see following section).

7.3.4 Selecting the bit rate

- 1 Press the up or down button to change the value (bit rate). The following bit rates are available:
 - 64 kbps
 - 96 kbps
 - 128 kbps
 - 192 kbps
 - 256 kbps
- 2 Press the select button to select the next value to change (see following section).

7.3.5 Set microphone to continuous recording

**Note**

If more than 50 delegate units are connected (by using additional control units), the option "record when one or more microphones are active" may not work correctly (also see section 5.2).

- 1 Press the down button to switch between constant recording or record when one or more microphones are active (see table 7.2).
- 2 Press the select button to select the next value to change (see following section).

7.3.6 Set internal/ external recording options

- 1 Press the down button to switch between record to the SD card or record to the internal memory (see table 7.2).
- 2 Press the change mode button (1) to exit the set-up mode.









7.4 Record

Use the record mode to record discussion. Before recording, make sure the SD card is inserted into the slot to the right of the display, or the unit is set to internal recording.

7.4.1 Overview of record icons

The following icons are displayed/used during recording.

table 7.3: Overview of record icons

Icon	Icon name	Function of icon
	Record selected	Shows the user that the Record mode is selected.
	Record	Starts recording session.
	Pause	Pauses recording session. When recording has been paused, the record icon will appear and start to flash. Press the record button to reactivate recording.
	Stop	Stops recording session
	New file	Creates a new file during recording (recording continues, but the data is saved under a new file name. The time counter on the display is also reset).
	Change card	Allows the user to change the SD card during recording (see section 7.4.3).
	Change card timer	Graphically shows the user how many seconds are remaining before the new card must be inserted.
	Hourglass	Icon will flash at 2Hz when the SD card is being initialized. During the initialization all control buttons are disabled.
	SD Card status	Card flashing at 2 Hz: card is missing. Card flashing at 5 Hz: card is either full, write protected, or incompatible. Note: This icon is not shown during the card exchange procedure or when the internal memory option is selected in the set-up mode. If during the card exchange procedure a card is not inserted within one minute of pressing the change card button, this icon will appear.

7.4.2 Making a recording

Make a recording as follows:

- 1 Press the change mode button to select the record mode. When selected, the record icon is shown in the top right-hand corner of the display.



Note

If the unit has just been powered up, the record mode is automatically selected.

- 2 Press the record button (2) to start recording. The blue LED next to the SD card holder will come on and the time counter will start.
- 3 During recording you can:
 - press the pause button (2) to temporarily halt recording.
 - press the stop button (3) to stop recording and close the recording session.
 - press the new file button (4) to create a new file.
 - change the SD card by pressing the change card button (5) on the display (see section 7.4.3).



Note

The record feature supports a maximum of 999 recorded files.

7.4.3 Exchanging SD cards during recording

The SD card can be changed at any time during recording, but the new card must be inserted within one minute of pressing the change card button (5). This allows discussion to continue even when the SD card is full. If the new card is not inserted within 1 minute, the card missing icon will be shown and recording will stop. The last minute of recorded discussion will also be lost.

When there is 5 minutes of recording time left on the card, three short beeps will be played through the monitor loudspeaker. This is to warn the operator to change the card. If the card is not changed within 5 minutes, a long beep will be played through the monitor loudspeaker at 0 minutes, and the card exchange function will automatically start.



Note

If a headphone is connected to the central unit, the beeps can only be heard via the headphone, and the blue LED will flash quickly (5Hz).

Change the card as follows:

- 1 Press the change card button (5).
The change card timer (see table 7.3) will then be shown in the middle of the display. You then have one minute to exchange the card. This is graphically shown by a clock icon, which starts to count down.
- 2 Remove the current card.
When the card is removed, the recorder will continue recording to the internal buffer of the recorder.
- 3 Insert the new card within one minute of pressing the change card button (5).
When the new card is inserted, a new file is automatically started using the current date and time as the file name. This file includes the previous 90 seconds of discussion (60 seconds from the internal buffer and the last 30 seconds of discussion from the previous card). This feature also allows transcription to take place off-line before the meeting has ended.

7.5 Pre-listen and Playback

Pre-listen and Playback are almost the same. The difference between these two modes is described below:

Pre-listen

Use the pre-listen mode to listen to discussion before playing it back to the floor. The audio signal is present at the monitor loudspeaker or the headphones, if connected.









Playback

Use the playback mode to play the discussion back to delegates. The audio signal is present at the monitor loudspeaker or the headphones, if connected, as well as at the delegate loudspeakers,

7.5.1 Overview of pre-listen/ playback icons

The following icons are displayed/used during pre-listening and playback.

table 7.4: Overview of pre-listen and playback icons

Icon	Icon name	Function of icon
	Pre-listen	When pre-listen is selected, this icon is shown at the top right-hand corner of the display.
	Playback	When playback is selected, this icon is shown at the top right-hand corner of the display.
	Start	Starts the pre-listen or playback session depending on mode selected. The first file in the list will be played. As soon as this file has been played, the next valid file will start.
	Pause	Pauses the pre-listen or playback session, depending on the mode selected. When pre-listen or playback has been paused, the start icon will appear and start to flash. Press the start button to continue with the session.
	Stop	Stops the pre-listen or playback session depending on the mode selected.
	Previous	Skips to previous file (also see fast rewind). Icon is only shown if a valid file is available. Note: Jumps to the last file in the list once the beginning of the list has been reached.
	Next	Skips to next file (also see fast forward). Icon is only shown if a valid file is available. Note: Jumps to the first file in the list once the end of the list has been reached.
	Fast rewind	Fast rewinds to the beginning of the file (10x normal speed). Icon will only appear if the previous button is pressed and held in for 2 seconds or longer.
	Fast forward	Fast forwards to the end of the file (10x normal speed). Icon will only appear if the next button is pressed and held in for 2 seconds or longer.

7.5.2 Pre-listening to and playing back files

To pre-listen to or playback files:

- 1 Press the change mode button (1) to select the required mode. The pre-listen or playback icon is shown in the top right-hand corner of the display, depending on the mode selected.
- 2 Press the start button (2) to pre-listen to or playback files. The MP3 tag is shown on the display. If there is no MP3 tag, the filename is shown instead.
- 3 During pre-listening or playback you can:
 - switch between pre-listen and playback, by pressing the change mode button (1).
 - press the pause button to temporarily halt playback.
 - press the stop button to stop pre-listening or playback.
 - skip to the previous track (press and hold to fast rewind).
 - skip to the next track (press and hold to fast forward).

8 Troubleshooting

Temporary no microphone reaction, and no sound or distorted sound from unit loudspeakers

- *Possible cause*
Trunk-line overload.
- *Solution*
Reduce load on the trunklines by reducing the number of units, and/or the length of the trunk cables.

Acoustic Feedback

- *Possible cause*
Loudspeaker volume too loud.
- *Solution*
 - Reduce gain using volume control for delegate/chairman unit loudspeakers on CU.
 - If available, switch on Digital Acoustic Feedback Suppression.
- *Possible cause*
Distance between units too small (microphone to loudspeaker of other units).
- *Solution*
 - Increase distance between units.
 - If available, switch on Digital Acoustic Feedback Suppression.
- *Possible cause*
Too close to microphone units, when using open headphones.
- *Solution*
 - Increase the distance between headphone and microphone or disconnect headphones when not in use.
 - If available, switch on Digital Acoustic Feedback Suppression.

Part of system not working

- *Possible cause*
Interrupted trunk-line cabling.
- *Solution*
Check the trunk-line cabling connections between the units and the CU, also use the test function on the CU.

No sound via delegate/chairman loudspeakers

- *Possible cause*
Insertion switch in wrong position.
- *Solution*
Check if insertion switch at the rear of the CU is in position "1".
- *Possible cause*
Volume control position.
- *Solution*
Check if the volume control for delegate/chairman loudspeakers on the CU is not in the fully counter clockwise position.
- *Possible cause*
Microphone active or headphone connected.



Note

Units with active microphone or connected headphone(s) have their loudspeakers switched off.

Hourglass flashes very fast

- *Possible cause*
The SD card is full.
- *Solution*
 - Check SD card, and remove files if necessary.
 - Use a PC to format the card. Use FAT or FAT32.
Note: NTFS is incompatible.
- *Possible cause*
The SD card is write protected.
- *Solution*
Remove SD card, and disable the write protection.
- *Possible cause*
The SD card is incompatible.
- *Solution*
Use a PC to format the SD card. Use FAT or FAT32.
Note: NTFS is incompatible.

Note: SD Cards larger than 2 GB are not supported.

Hourglass flashes for a long time after inserting the SD Card

- *Possible cause*
The SD card is almost full.
- *Solution*
 - Remove old files/recordings.
 - Format the SD card.
- *Possible cause*
The SD card is too slow.
- *Solution*
Use a faster SD card.

Recorded files missing on SD card

- *Possible cause*
The SD card was removed during recording.
- *Solution*
 - Always stop recording before removing SD card.
 - Select SD card exchange before removing SD card.

User display is blank

- *Possible cause*
During CU power up, the USB cable was connected to the CU and PC, while the PC was switched off.
- *Solution*
 - Make sure the USB cable is not connected during CU power up.
 - Make sure the PC is fully operational before connecting the USB cable.

9 Technical data

9.1 System Electrical and Electro-Acoustical Characteristics

9.1.1 The CU

Mains voltage: 100 - 240 Vac, ± 10%, 50/60 Hz
 Current consumption: max. 0.9 A (100 Vac) - 0.3 A (240 Vac)

Power Consumption: 60 W

DC supply to contribution units: 24V +/- 1V (current limited)
 Rated output for all trunks 1.25A

Sample frequency:
 - Recording 32 Khz
 - Playback 32, 44.1 and 48 Khz

Bite rate:
 - Recording 64, 96, 128, 192 , 256 Kbit/sec
 - Playback any bitrate

Media:
 - MP3-tag Compatible conform ID3V2
 - Memory card Any SD Card up to 2 Gb (high speed cards are advised)

Recording capacity:

Bit rate	Card size		
	512 MB	1 GB	2 GB
64	17h:14m	34h:28m	64h:56m
96	11h:29m	22h:59m	45h:58m
128	8h:37m	17h:14m	34h:28m
192	5h:44m	11h:29m	22h:58m
256	4h:18m	8h:37m	17h:14m

Line, telephone coupler and insertion in/outputs (unbalanced)

Input sensitivity: -14 dBV/ +11dBV (nominal/maximum)
 Input impedance: 33 kΩ
 Output level: -14 dBV/ +11dBV (nominal/maximum)
 Output impedance: 500 Ω

Recorder in/output (unbalanced) - mono

Input sensitivity: - 20 dBV/ + 5 dBV (nominal/maximum)
 Input sensitivity adjustment: +0 / -20 dB
 Input impedance: 47 kΩ (for L and R channel)
 Output level: - 20 dBV/ + 5 dBV (nominal/maximum)
 Output impedance: 500 Ω

External microphone input (balanced)

Input sensitivity: - 56 dBV (- 6 dBV via included adapter).
 Input sensitivity adjustment: +6 dB / -6 dB
 Phantom supply: 12V +/- 1V, 2 x 680 Ω (+/-2%). (Phantom supply is not available when using the included adapter).

Monitor loudspeaker

Output level at 0.5 m: 72 dB SPL/ 82 dB SPL (nominal/maximum)
 Frequency response: 320 Hz ... 10 kHz (-10 dB, ref. 1kHz)
 Impedance: 25 Ω
 Volume control: 50 dB attenuation range

Monitor headphone

Output level: -8 dBV/ +2 dBV (nominal/maximum)
 Output impedance: 22 Ω
 Output connection: stereo jack socket (mono output)
 Allowed impedance: any impedance
 Volume control: 50 dB attenuation range

Loudspeaker volume control

For delegate and chairman units: mute (50 dB att.) + 10 steps of 1.9 dB

Limiter threshold level

To unit loudspeaker /headphone: 10 dB above nominal level

Gain reduction due to NOM

(Number of Open Microphones): $\sqrt{\text{NOM}} \pm 1 \text{ dB}$

Auto microphone switch-off function selectable on the Control and Power Supply Unit

After approximately 30 sec. not speaking (sound level below 64 dB SPL) the microphone is automatically switched off

System limits

Number of delegate/chairman units connected to CU

Maximum in total: 50

Maximum per

trunk output: 25

Maximum trunk length

using CCS 800 Ultro

standard cabling: 100 m (328 ft)

9.1.2 Combined Units

Delegate microphones with transmission links to delegate headphones and auxiliary outputs.

General

Frequency response: 125 Hz - 12.5 kHz tolerances
acc. to IEC 914 standard

Total harmonic distortion at overload

at nominal input

level (85 dB SPL): < 0.5%

at max. input

level (110 dB SPL): < 3%

9.2 Mechanical Data

9.2.1 Control and Power Supply Unit

Mounting: free standing on a table top or mounted in a 19" rack (requires 3HU (Height Units) with bracket set LBB 3311/00). Information about how to make the necessary brackets for table flush mounting is included.

Dimensions(HxWxD): 84 x 361 x 143 mm (with 5.5 mm feet)

3.4 x 14.2 x 5.6 in (with 0.22 in feet).

Weight: /00 version 1.5 kg (3.3 lb)

/10 version 1.7 kg (3.8 lb)

9.2.2 Delegate/Chairman Units

Dimensions (w x d x h)

without mic.: 124 x 172 x 63 mm
(4.9 x 6.8 x 2.5 in)

Length of mic. from

mounting surface: /00 version, 313 mm (12.3 in)
/50 version, 488 mm (19.2 in)

Weight: 0.9 kg (2.0 lb)

9.3 General Data

9.3.1 System Environmental Conditions

Temperature range

Storage and transport: -20 to +70°C (-4 to +158°F)

Operational: +5 to +45°C (+41 to 113°F)

Ambient humidity

Operational: 20% - 95% RH

Storage and transport: 0% - 99% RH

Air pressure: 600 mBar - 1100 mBar

Safety: acc. to EN 60065 and acc. to UL 60065

Resistance to shock, vibration, bump and transport: acc. to IEC 60068, 5G acceleration

EMC emission: acc. to EN 55103-1 and FCC rules (part 15), class A

EMC immunity: acc. to EN 55103-2

EMC approvals: affixed with the CE mark

Mains harmonics: EN 61000-3-2 and EN61000-3-3

Transport: AV18-Q0681

9.3.2 Equipment Range

Control and power

supply unit: CCS-CU
 CCS-CUD (with Digital Acoustic Feedback Suppression)
 CCS-CUR (with recording)
 CCS-CURD (with recording and Digital Acoustic Feedback Suppression)

19" rack mounting set: LBB 3311/00

Bracket for flush

mounting: can be made locally according to the illustration in 9 Appendix

Delegate unit(s): LBB 3330/00
 LBB 3330/50
 (with long microphone)

Chairman unit(s) : LBB 3331/00
 LBB 3331/50
 (with long microphone)

Installation cable with connectors LBB 3316/00 (100 m)

Extension cables : LBB 3316/05 (5m)
 LBB 3316/10 (10m)

Cable locking clamps :LBB 4117/00 (set of 25 pieces)

Transport suitcase for 10 delegate/chairman units with standard microphone: LBB 3312/00

Transport suitcase for one CU, 6 delegate/chairman units with standard and/or long microphone and some extension cables: LBB 3312/10

10 Appendix

10.1 Pin Configuration

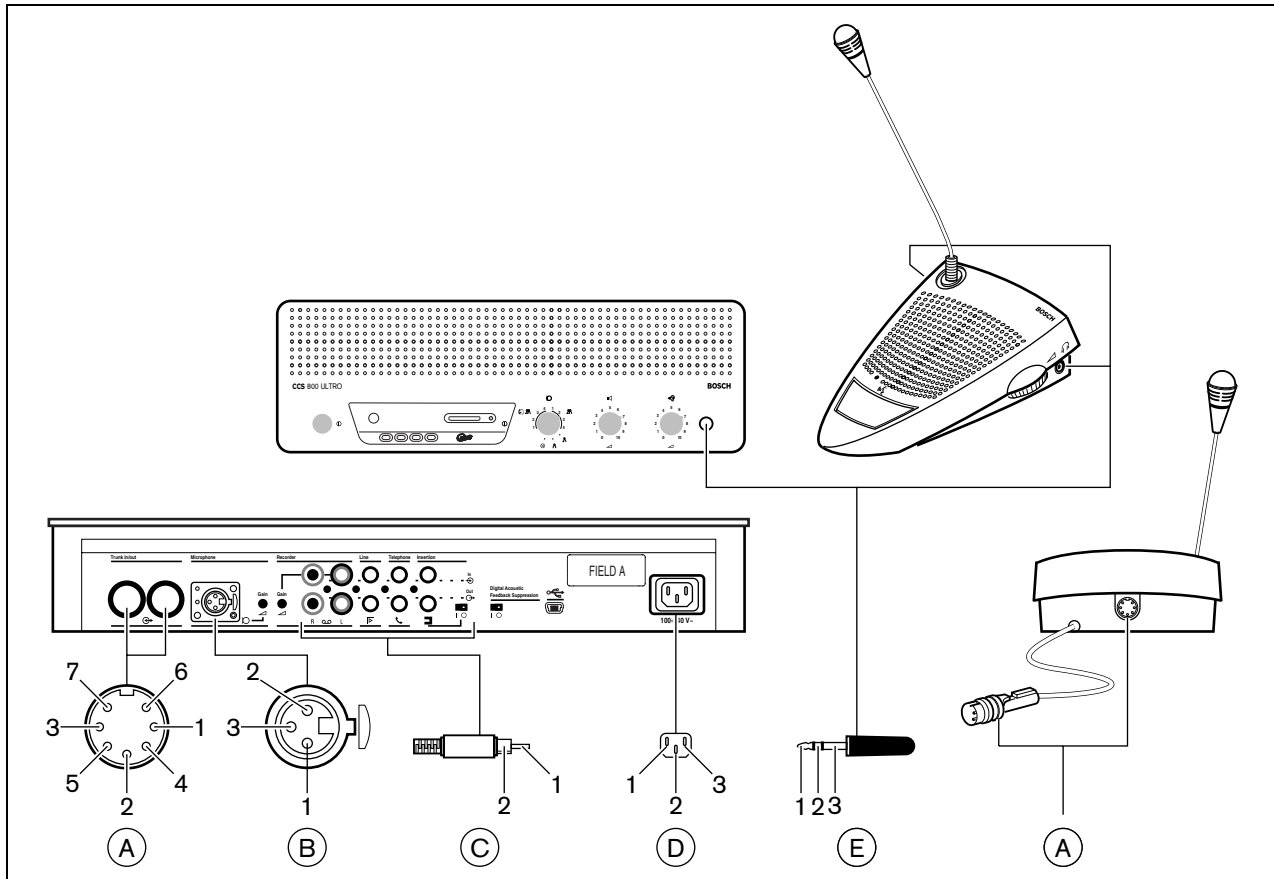

Figure 10.1

10.1.1 Trunk Connections (A)

- 1 Audio contribution line
- 2 GND
- 3 Audio distribution line
- 4 Control line 1
- 5 Control line 2
- 6 V+ supply
- 7 V- supply

10.1.2 External Microphone (XLR) (B)

- 1 GND (0V, phantom supply)
- 2 Signal + (+12V, phantom supply)
- 3 Signal - (+12V, phantom supply)
phantom supply acc. to DIN45596

10.1.3 CINCH Connector (C)

- 1 Signal +
- 2 Screen

10.1.4 Mains Connector (D)

- 1 Mains
- 2 Earth
- 3 Mains

10.1.5 Headphone Jack-plug (3.5mm) (E)

- 1 Tip - Signal +
- 2 Ring - Signal -
- 3 Sleeve - Electrical earth/screen

10.1.6 Mounting of connectors, LBB 3316/00

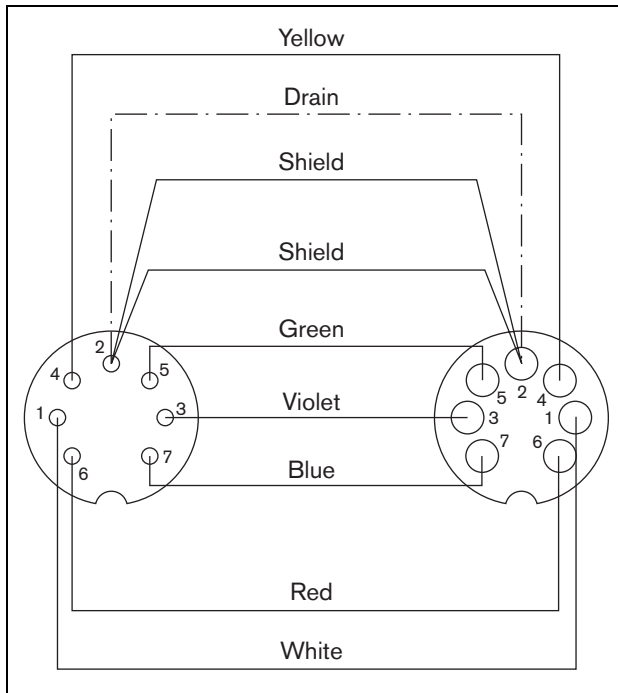

Figure: 10.2

The CU can be attached in three different ways:

- In a 19" rack making use of the 19" rack mounting set LBB 3311/00. Place a blank 1HU panel above the CU to have sufficient space for cable connections.
- Mounted into a table using the flush mount bracket.
- On a table. Therefore drill four holes in the table and fasten the CU with four M3 screws (B).

The delegate and chairman units can only be attached on a table. Therefore drill two holes in the table and fasten the unit with two M3 screws (A).

Note
When the device is attached to a flat surface it no longer conforms to the UL/CSA approval.

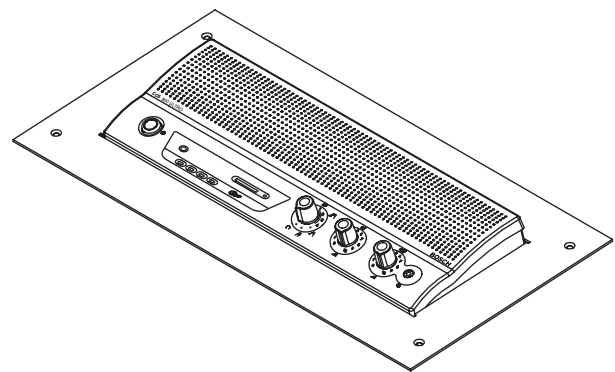

Figure 10.3

10.2 Mounting Instructions

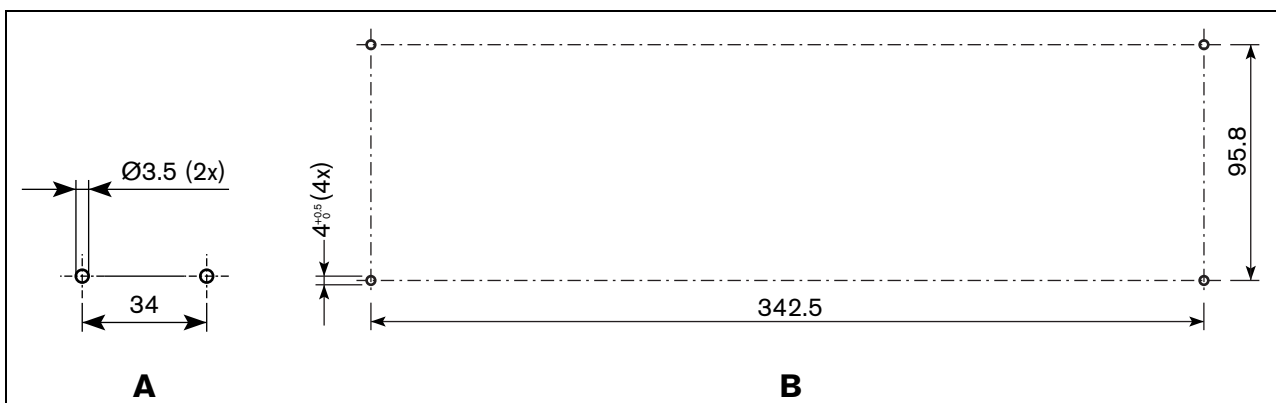

Figure: 10.4

10.3 Bracket for Flush Mounting

The drawing below gives the necessary information how to make a bracket for flush mounting the CU into a table.

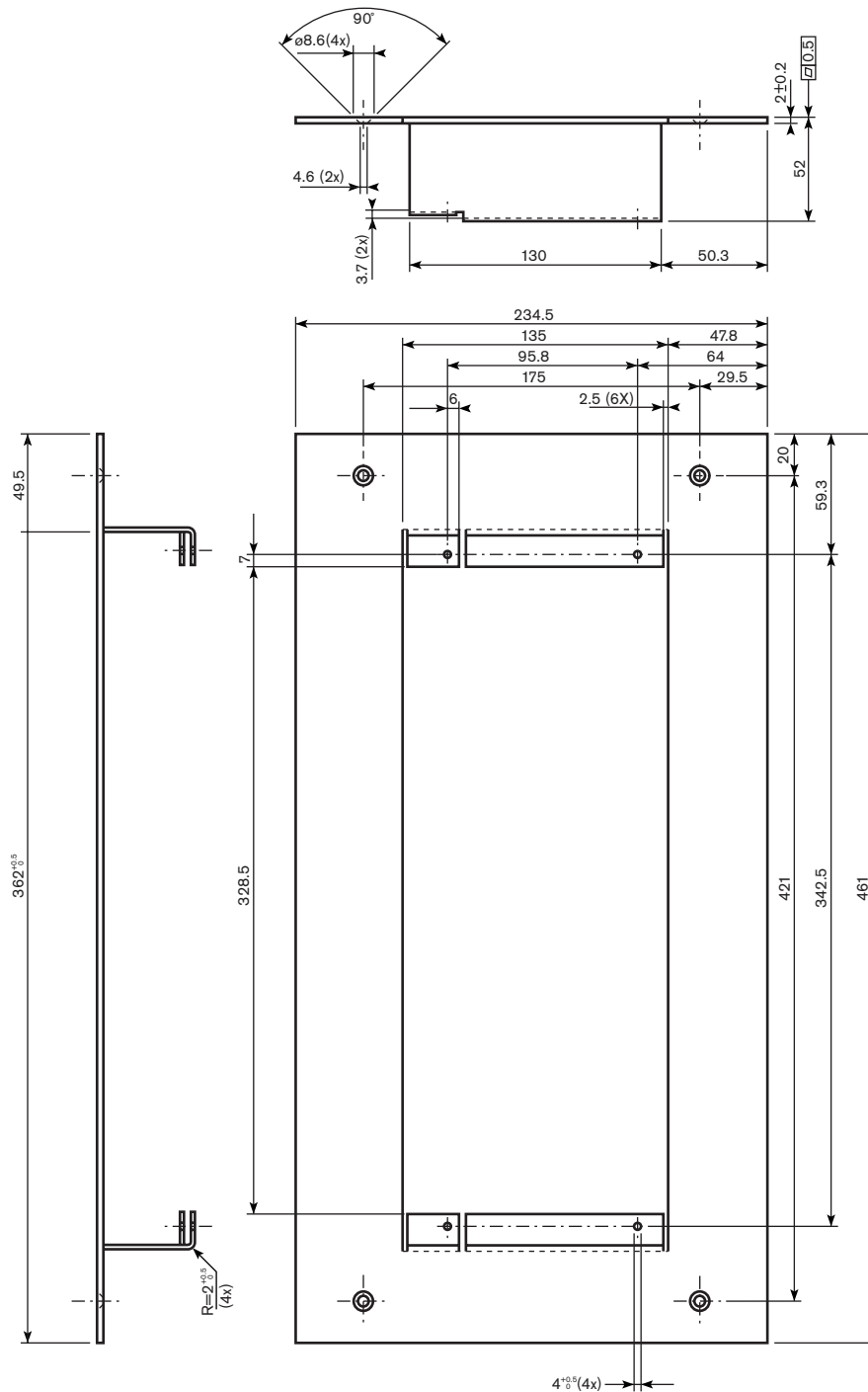

Figure: 10.5

For more information visit www.boschsecurity.com

© Bosch Security Systems B.V.

Data subject to change without notice

2007-08



BOSCH